

**A unique range of anchors specifically designed  
for the Fit Out and MEP trades**

## INDEX

### **SureHit for Concrete –**

Suspended Ceilings, Fire Protection Boards and Insulation, M&E Equipment.

**Page 3 - 16**



### **SureHit for Concrete – Sprayed Concrete Reinforcement.**

**Page 17 - 19**

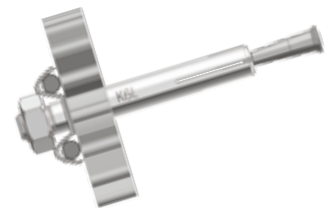

### **SureHit for Concrete – Acoustic Fixings and Hangers.**

**Page 20 - 22**



### **SureHit for Hollow Concrete Slabs – Fixing and Hanger**

**Page 23 - 24**



### **SureHit for Aircrete.**

**Page 25 - 26**



### **SureHit for Concrete – Tunnel Radio Cable Fixing**

**Page 27**



CONSTRUCTION PRODUCTS SOLUTIONS INTERNATIONAL LTD.

Unit 3, Haslemere Industrial Estate, Pig Lane, Bishop's Stortford, Hertfordshire. CM23 3HG. United Kingdom.  
Tel: +44(0)1279 505 514 - Fax: +44(0)1279 755190 - e mail: [info@surecps-group.com](mailto:info@surecps-group.com) - [www.surecps-group.com](http://www.surecps-group.com)  
Company Reg. 6969591 VAT Reg. GB 824 4246 40



Please always wear the appropriate safety and protective clothing when installing fixing and anchor products. Always observe the necessary Health & Safety guidelines.

© All text copyright. Above information is given as guidance only and should always be verified by a suitable engineer.

The above information is given in good faith, and may be subject to alteration at any time without prior notification.

Drill hole with the corresponding stop drill bit:



Stop drill bit and corresponding anchor

The Surehit consists of two components:

- the stop drill bit
- the anchor (can include attachment).

Stop drill bit supplied to drill the correct diameter and depth.

The stop drill bit corresponds to the anchor, resulting in the correct depth as well as hole diameter being drilled each time.

**This ensures peace of mind:** With all anchors, the min. drill hole depth is ensured the surehit anchor with corresponding stop drill bit, achieves this.

The installation of the anchor is as follows.

With a hammer

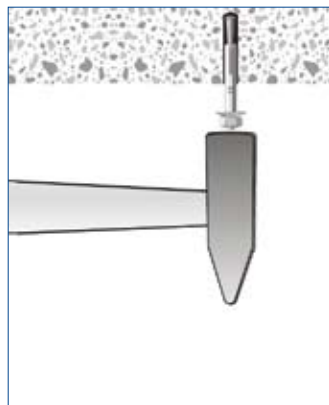

With the respective anchor size – KDM-KDM 6 x .../N.

With the setting tool

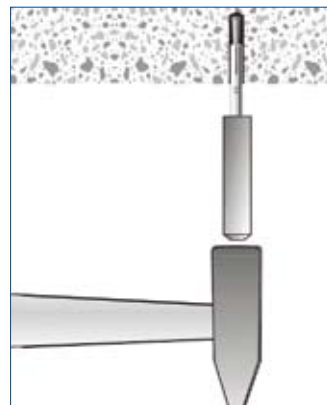

All anchors can be set using the hand held setting tool

With the setting tool and drill bit



To decrease installation time, the anchor can be installed using the setting tool mounted on the drill bit

\* Permissible load in accordance to ETA/ -04/ 0026. Suitable for non-load bearing applications  
Total partial safety anchor in accordance to ETAG ( $Y_M$  &  $Y_F$ )

CONSTRUCTION PRODUCTS SOLUTIONS INTERNATIONAL LTD.

Unit 3, Haslemere Industrial Estate, Pig Lane, Bishop's Stortford, Hertfordshire. CM23 3HG. United Kingdom.  
Tel: +44(0)1279 505 514 - Fax: +44(0)1279 755190 - e mail: info@surecps-group.com - www.surecps-group.com  
Company Reg. 6969591 VAT Reg. GB 824 4246 40



Please always wear the appropriate safety and protective clothing when installing fixing and anchor products. Always observe the necessary Health & Safety guidelines.

© All text copyright. Above information is given as guidance only and should always be verified by a suitable engineer.

The above information is given in good faith, and may be subject to alteration at any time without prior notification.

## THE SUREHIT ANCHOR

Drill



Clean - Attach setting tool

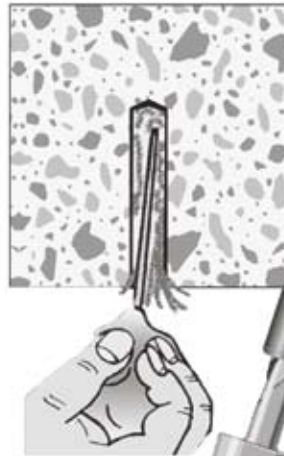

Hammer into place

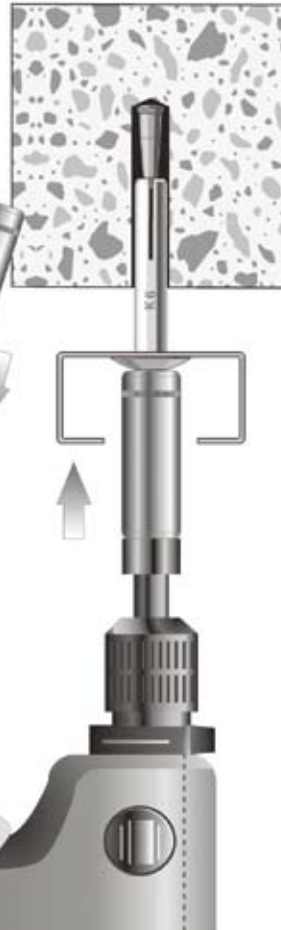

Done



### Installation advantages:

1. Installation errors are all but eliminated

The anchor and matching installation tools ensure no installation errors.

2. Saving time and material

Each SureHit stop drill bit suits the selected anchor to ensure the correct anchor hole depth.

3. Approved safety

SureHit anchors meet all technical requirements:  
 ✓ ETA approval.

4. Problem solving solution

The SureHit system is so versatile it will overcome almost all installation problems.

CONSTRUCTION PRODUCTS SOLUTIONS INTERNATIONAL LTD.

Unit 3, Haslemere Industrial Estate, Pig Lane, Bishop's Stortford, Hertfordshire. CM23 3HG. United Kingdom.  
 Tel: +44(0)1279 505 514 - Fax: +44(0)1279 755190 - e mail: info@surecps-group.com - www.surecps-group.com  
 Company Reg. 6969591 VAT Reg. GB 824 4246 40



Please always wear the appropriate safety and protective clothing when installing fixing and anchor products. Always observe the necessary Health & Safety guidelines.

© All text copyright. Above information is given as guidance only and should always be verified by a suitable engineer.

The above information is given in good faith, and may be subject to alteration at any time without prior notification.

## PRE-FIX OR THROUGH-FIX INSTALLATION

Drill with the appropriate SureHit stop drill bit

For this example the stop drill bit will sit against the surface of the drill hole (see opposite)

Installation procedure

- ▣ Drill the hole
- ▣ Install the anchor and attachment



For through fixing installations using either the KDM or KDM/L

The anchor is installed through the attachment

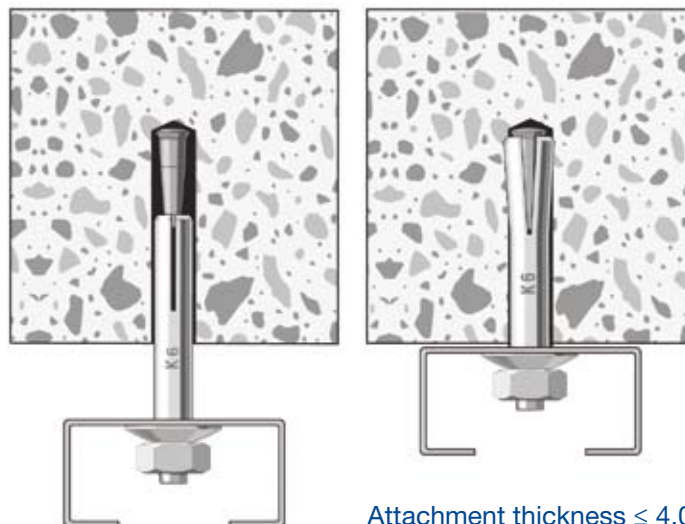

\* Permissible load in accordance to ETA/-04/ 0026. Suitable for non-load bearing applications

Total partial safety anchor in accordance to ETAG ( $Y_M$  &  $Y_F$ )

### CONSTRUCTION PRODUCTS SOLUTIONS INTERNATIONAL LTD.

Unit 3, Haslemere Industrial Estate, Pig Lane, Bishop's Stortford, Hertfordshire. CM23 3HG. United Kingdom.  
 Tel: +44(0)1279 505 514 - Fax: +44(0)1279 755190 - e mail: info@surecps-group.com - www.surecps-group.com  
 Company Reg. 6969591 VAT Reg. GB 824 4246 40

Please always wear the appropriate safety and protective clothing when installing fixing and anchor products. Always observe the necessary Health & Safety guidelines.

© All text copyright. Above information is given as guidance only and should always be verified by a suitable engineer.

The above information is given in good faith, and may be subject to alteration at any time without prior notification.





## THROUGH FIXING INSTALLATION

For through fixing the drill hole is made through the attachment. The anchor is therefore installed through the attachment into the concrete.

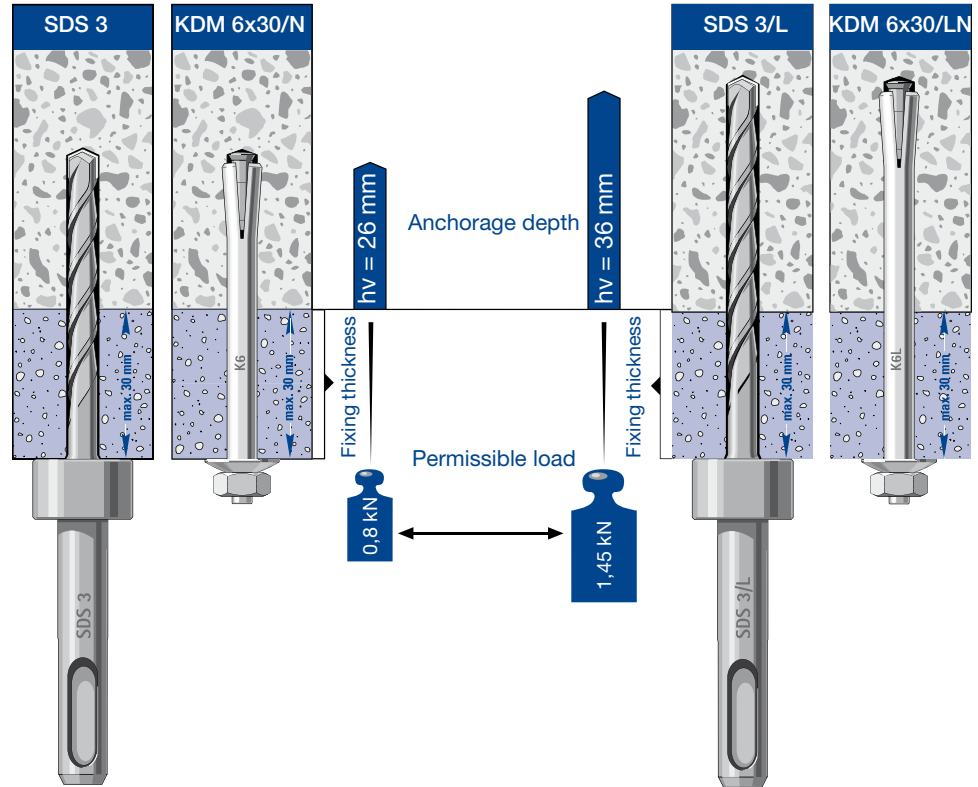

Match the stop drill to the anchor

	Description	Fixing thickness mm	Drill hole depth mm	Usable length mm	Per. load kN
Drill hole depth 32 mm	SDS 3	30	32	62	0.8
=	SDS 3/L	40	32	72	0.8
Anchorage depth 26 mm	SDS 4	50	32	82	0.8
=	SDS 4/L	60	32	92	0.8
Perm. Load 0.8 kN*	SDS 5	80	32	112	0.8
	SDS 5/L	90	32	122	0.8
	SDS 6	100	32	142	0.8
Drill hole depth 42 mm	SDS 3	20	42	62	1.45
=	SDS 3/L	30	42	72	1.45
Anchorage depth 36 mm	SDS 4	40	42	82	1.45
=	SDS 4/L	50	42	92	1.45
Perm. Load 1.45 kN*	SDS 5	70	42	112	1.45
	SDS 5/L	80	42	122	1.45
	SDS 6	100	42	142	1.45

\* Permissible load in accordance to ETA/ -04/ 0026. Suitable for non-load bearing applications  
Total partial safety anchor in accordance to ETAG ( $Y_M$  &  $Y_F$ )

### CONSTRUCTION PRODUCTS SOLUTIONS INTERNATIONAL LTD.

Unit 3, Haslemere Industrial Estate, Pig Lane, Bishop's Stortford, Hertfordshire. CM23 3HG. United Kingdom.  
Tel: +44(0)1279 505 514 - Fax: +44(0)1279 755190 - e mail: info@surecps-group.com - www.surecps-group.com  
Company Reg. 6969591 VAT Reg. GB 824 4246 40



Please always wear the appropriate safety and protective clothing when installing fixing and anchor products. Always observe the necessary Health & Safety guidelines.

© All text copyright. Above information is given as guidance only and should always be verified by a suitable engineer.

The above information is given in good faith, and may be subject to alteration at any time without prior notification.

## SUREHIT ANCHOR SYSTEM FOR FIRE PROTECTION APPLICATIONS

Fire tests with anchors are the most onerous that an individual fixing is expected to endure. Since 1984 regular fire testing of Surehit anchors has taken place.

The tests with the Surehit have been carried out in accordance with the so called 'Uniform Temperature Curve' [ETK].

At the same time, additional temperature curves can be observed for special conditions. In certain cases, such as tunnel construction, the additional requirements are even more onerous. The conditions of the behaviour of fires in tunnels are measured in different ways for each respective country. This can be seen from the diagram below.

The Surehit anchors are tested in accordance to the Rijkswaterstaat Tunnel Fire Curve [RWS].

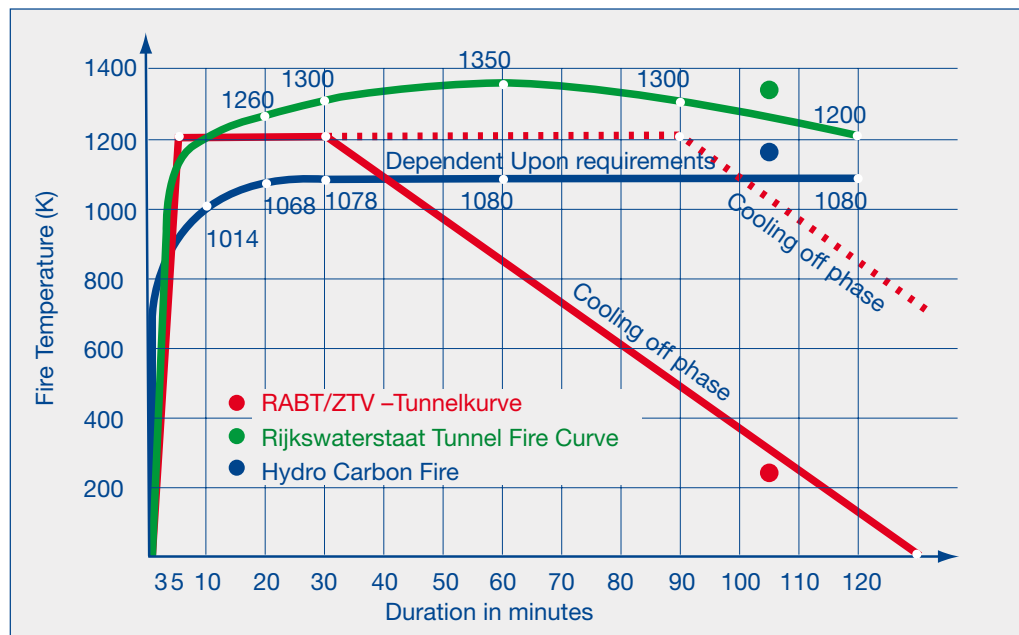

SureHit is covered by a European Technical Approval. The shallow installation depth removes the need for powder-actuated (shot-fired) fixings. SureHit is suitable for the installation of dry lining, partitioning and fire protection boards and also for suspended ceiling and lighting applications. It is compliant with the requirements of London Underground Standard 1-085 'Fire Safety Performance of Materials' and can be used in below ground stations.

\* For use with non – load bearing systems with multiple fixings in cracked concrete.  
Total partial safety anchor in accordance to ETAG ( $Y_M$  &  $Y_F$ )

### CONSTRUCTION PRODUCTS SOLUTIONS INTERNATIONAL LTD.

Unit 3, Haslemere Industrial Estate, Pig Lane, Bishop's Stortford, Hertfordshire. CM23 3HG. United Kingdom.  
Tel: +44(0)1279 505 514 - Fax: +44(0)1279 755190 - e mail: info@surecps-group.com - www.surecps-group.com  
Company Reg. 6969591 VAT Reg. GB 824 4246 40



## K CONCRETE ANCHOR FOR THE ATTACHMENT OF SUSPENDED CEILING, METAL WORK AND EQUIPMENT

SureHit suspended ceiling fixings – KDM - /KDM/L

### Application:

For the attachment of all kinds of cleats and brackets used for suspended ceilings.

Available in the following materials

Zinc plated and Passivated steel

Stainless Steel A4 1.4404

Stainless Steel A5 1.4571

Stainless Steel A6 1.4529

Perm. Load to approval ETA - 04/0026\*

KDM 0.80 kN

KDM/L 1.45 kN



Soffit fixing	KDM	KDM-Set
Fixing thickness ≤ mm	4	4
Item number	KSH7001	KSH7002
Box Qty	200	200
Stop drill	SDS 1	SDS 1
Item number	KSH11002	KSH11002
Hand held setting tool	SWM-H	SWM-H
Item number	KSH10007	KSH10007
Stop drill setting tool	SWM-SM 16	SWM SM 16
Item number	KSH10207	KSH10207

Contents set: 200 KDM anchors and 1 Stop Drill SDS 1

Soffit fixing	KDM/L	KDM/L-Set
Fixing thickness ≤ mm	4	4
Item number	KSH7101	KSH7020
Box Qty.	100	200
Stop drill	SDS 2	SDS 2
Item number	KSH7002	KSH7002
Hand held setting tool	SWM-H	SWM-H
Item number	KSH10007	KSH1007
Stop drill setting tool	SWM-SM 16	SWM SM 16
Item number	KSH10207	KSH10207

Contents set: 200 KDM anchors and 1 STOP DRILL SDS 2

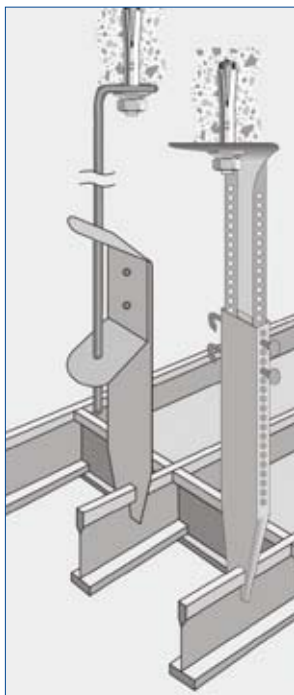

\* Permissible load in accordance to ETA/ -04/ 0026. Suitable for non-load bearing applications

Total partial safety anchor in accordance to ETAG (Y<sub>M</sub> & Y<sub>F</sub>)



Stop drill SDS 1



SWM - H



Stop drill SDS 2



SWM - SM 16

### CONSTRUCTION PRODUCTS SOLUTIONS INTERNATIONAL LTD.

Unit 3, Haslemere Industrial Estate, Pig Lane, Bishop's Stortford, Hertfordshire. CM23 3HG. United Kingdom.  
Tel: +44(0)1279 505 514 - Fax: +44(0)1279 755190 - e mail: info@surecps-group.com - www.surecps-group.com  
Company Reg. 6969591 VAT Reg. GB 824 4246 40



Please always wear the appropriate safety and protective clothing when installing fixing and anchor products. Always observe the necessary Health & Safety guidelines.

© All text copyright. Above information is given as guidance only and should always be verified by a suitable engineer.

The above information is given in good faith, and may be subject to alteration at any time without prior notification.



## KDA CONCRETE FIXING FOR SUSPENDED CEILING

### Application:

For the attachment of wire hangers used for suspended ceilings.

Available in the following materials:

Zinc plated and passivated carbon steel

Perm. load to approval ETA - 04/0026\*

KDM 0.80 kN

KDM/L 1.45 kN



Drill hole depth 32mm



Drill hole depth 42mm

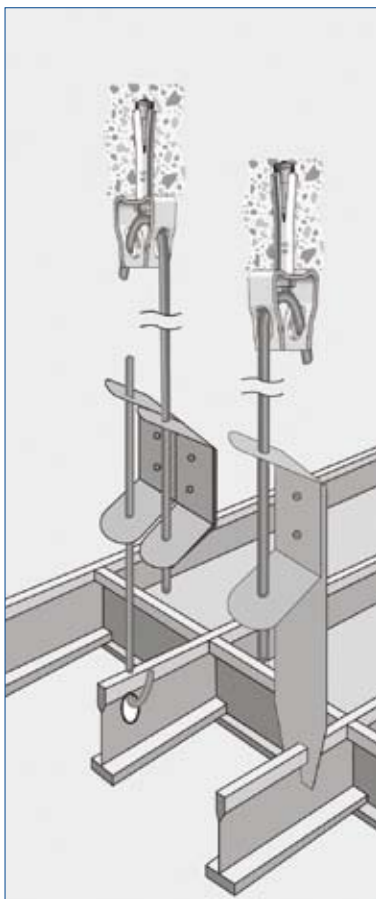

Soffit fixing	KDA	KDA/Set	KDA-L
Item number	KSH7008	KSH7009	KSH7108
Box qty	100	200	100
Stop drill	SDS 1	SDS 1	SDS 2
Item Number	KSH11002	KSH11002	KSH1107
Stop drill setting tool	SWA-SM	SWA-SM	SWA-SM
Item number	KSH10205	KSH10205	KSH10205

Contents set: 200  
KDM anchors  
+ 1 Stop drill SDS 1



Stop drill SDS 1



Stop drill SDS 2



SWA - SM

\* Permissible load in accordance to ETA/ -04/ 0026. Suitable for non-load bearing applications

Total partial safety anchor in accordance to ETAG (Y<sub>M</sub> & Y<sub>F</sub>)

### CONSTRUCTION PRODUCTS SOLUTIONS INTERNATIONAL LTD.

Unit 3, Haslemere Industrial Estate, Pig Lane, Bishop's Stortford, Hertfordshire. CM23 3HG. United Kingdom.  
Tel: +44(0)1279 505 514 - Fax: +44(0)1279 755190 - e mail: info@surecps-group.com - www.surecps-group.com  
Company Reg. 6969591 VAT Reg. GB 824 4246 40



Please always wear the appropriate safety and protective clothing when installing fixing and anchor products. Always observe the necessary Health & Safety guidelines.

© All text copyright. Above information is given as guidance only and should always be verified by a suitable engineer.

The above information is given in good faith, and may be subject to alteration at any time without prior notification.

## KDM CONCRETE FIXING FOR FIRE PROTECTION BOARDS AND SIMILAR MATERIALS

SureHit fire protection board fixing KDM 6.

### Application:

For the attachment of fire protection board in conjunction with a 40mm steel insulation disc.

Available in the following materials:

Zinc plated and Passivated steel

Stainless steel A4 1.4404

Stainless steel A5 1.4571

Stainless steel A6 1.4529

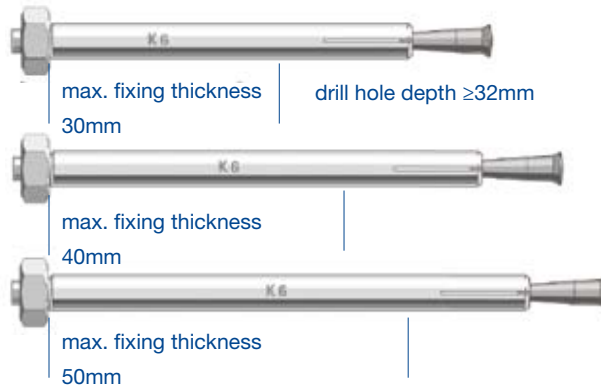

Fire protection fixing	KDM 6 x 30	KDM 6 x 40	KDM 6 x 50
Fixing thickness ≤ mm	30	40	50
Item Number	KSH7301	KSH7303	KSH7302
Box qty.	100	100	100
Stop drill	SDS 3F	SDS 3 LF	SDS 4F
Item number	KSH11018	KSH11026	KSH11019
Setting tool	hand held	hand held	hand held

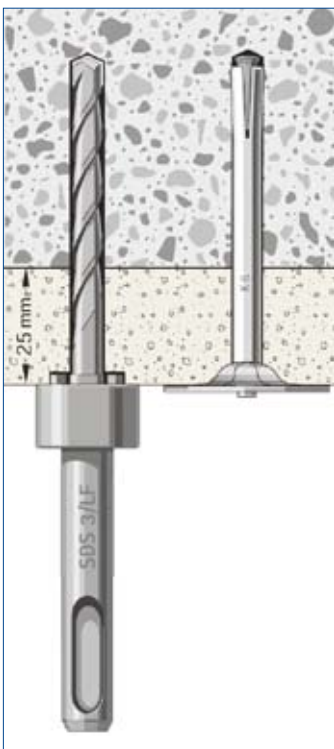

Suitable for fixing  
KD 6 x KDM 6 x ...

Insulation disc	80 x 80mm	Ø 40mm
Availability	Item Number	Item Number
Bright zinc plated	KSH17055	KSH17049
Black zinc plated	KSH17056	
Stainless steel A4	KSH17057	
Stainless steel 1.4539		KSH17058

\* Permissible load in accordance to the ETA/-04/0026.

Suitable for non-load bearing applications

Total partial safety anchor in accordance to ETAG ( $Y_M$  &  $Y_F$ )



Stop drill SDS 3F / SDS 3LF



Stop drill SDS 4F

### CONSTRUCTION PRODUCTS SOLUTIONS INTERNATIONAL LTD.

Unit 3, Haslemere Industrial Estate, Pig Lane, Bishop's Stortford, Hertfordshire. CM23 3HG. United Kingdom.  
Tel: +44(0)1279 505 514 - Fax: +44(0)1279 755190 - e mail: info@surecps-group.com - www.surecps-group.com  
Company Reg. 6969591 VAT Reg. GB 824 4246 40



Please always wear the appropriate safety and protective clothing when installing fixing and anchor products. Always observe the necessary Health & Safety guidelines.

© All text copyright. Above information is given as guidance only and should always be verified by a suitable engineer.

The above information is given in good faith, and may be subject to alteration at any time without prior notification.

## TYPICAL APPLICATIONS TO ATTACH FIRE PROTECTION BOARDS



A range of products for fire protection applications in tunnels and structures.



Small SureHit used to attach fire protection board.



Completed tunnel project, using the Surehit to attach fire protection board and radio cable throughout.



Work in progress.

### CONSTRUCTION PRODUCTS SOLUTIONS INTERNATIONAL LTD.

Unit 3, Haslemere Industrial Estate, Pig Lane, Bishop's Stortford, Hertfordshire. CM23 3HG. United Kingdom.  
Tel: +44(0)1279 505 514 - Fax: +44(0)1279 755190 - e mail: info@surecps-group.com - www.surecps-group.com  
Company Reg. 6969591 VAT Reg. GB 824 4246 40



Please always wear the appropriate safety and protective clothing when installing fixing and anchor products. Always observe the necessary Health & Safety guidelines.

© All text copyright. Above information is given as guidance only and should always be verified by a suitable engineer.

The above information is given in good faith, and may be subject to alteration at any time without prior notification.

## KDM FIRE RATED CONCRETE FIXING FOR FIRE PROTECTION BOARDS AND SIMILAR MATERIALS

### Applications:

All kinds of installations requiring a fire rated fixing for the installation of partitions, dry lining, suspended ceilings and fire rated panel and boards.

### Range of materials:

Bright zinc plated carbon steel and the following stainless steels: A4 - 1.4404, A5 - 1.4571. For extreme conditions such as chlorine contaminated atmospheres or road tunnels the A6 - 1.4529 material is available.

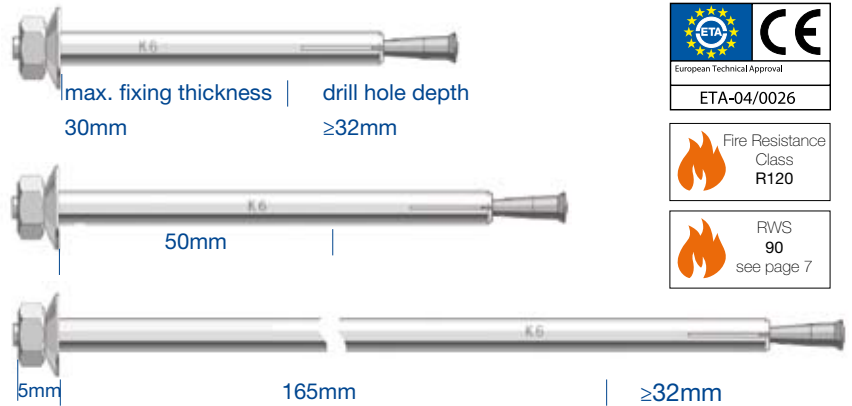

FIRE PROTECTION FIXING	KDM 6x30/N	KDM 6x40/N	KDM 6x50/N	KDM 6x60/N	KDM 6x80/N	KDM 6x90/N	KDM 6x110/N
Max. Fixing thickness ≤ mm	30	40	50	60	80	90	110
Item number	KSH7309	KSH7311	KSH7310	KSH7312	KSH7313	KSH7315	KSH7314
Box qty/pieces	100	100	100	100	50	50	50
Stop Drill Bit	SDS 3	SDS 3/L	SDS 4	SDS 4/L	SDS 5	SDS 5/L	SDS 6
Item number	KSH11012	KSH11023	KSH11013	KSH11025	KSH11014	KSH11024	KSH11015
Stop drill setting tool	SWM-SM50	SWM-SM50	SWM-SM50	SWM-SM50			
Item number	KSH10206	KSH10206	KSH10206	KSH10206			
Hand held setting tool	SWM-H	SWM-H	SWM-H	SWM-H	SWM-H	SWM-H	SWM-H
Item number	KSH10007	KSH10007	KSH10007	KSH10007	KSH10007	KSH10007	KSH10007



Stop drill SDS 3 – SDS 6

### \* Permissible loads:

In accordance with the ETA-04/0026 \*  
KDM 6x... /N 0,80 kN

\*Also suitable for non-load bearing applications requiring multiple fixing points.Total partial safety anchor in accordance to ETAG (Y<sub>M</sub> & Y<sub>F</sub>)



SWM/H



SWM-SM 50

### CONSTRUCTION PRODUCTS SOLUTIONS INTERNATIONAL LTD.

Unit 3, Haslemere Industrial Estate, Pig Lane, Bishop's Stortford, Hertfordshire. CM23 3HG. United Kingdom.  
Tel: +44(0)1279 505 514 - Fax: +44(0)1279 755190 - e mail: info@surecps-group.com - www.surecps-group.com  
Company Reg. 6969591 VAT Reg. GB 824 4246 40



Please always wear the appropriate safety and protective clothing when installing fixing and anchor products. Always observe the necessary Health & Safety guidelines.

© All text copyright. Above information is given as guidance only and should always be verified by a suitable engineer.

The above information is given in good faith, and may be subject to alteration at any time without prior notification.



## K CONCRETE FIXING FOR SUSPENDED CEILING, CLEATS AND BRACKETS

### SureHit bolt anchor M6

#### Application:

For the attachment of objects to the surface of thick insulation (Through fixing)

#### Available in the following materials:

Zinc plated and passivated Carbon Steel  
 Stainless steel A4 1.4404  
 Stainless steel A5 1.4571  
 Stainless steel A6 1.4529

The long fixing thickness allows the anchor to attach items to thick insulation.



Bolt Fixing	K 6x5	K 6x15	K 6x30	K 6x50/30	K 6x80/50	K 6x110/50
Item number	KSH7199	KSH7200	KSH7201	KSH7210	KSH7211	KSH7212
Box qty	200	100	100	100	100	100
Stop drill	SDS 1	SDS 1	SDS 1	SDS 1	SDS 1	SDS 1
Item number	KSH11002	KSH11002	KSH11002	KSH11002	KSH11002	KSH11002
Hand held setting tool	EWA 6 x 5	EWA 6 x 15	EWA 6 x 30	EWA 6 x 50	EWA 6 x 80	EWA 6 x 110
Item number	KSH10099	KSH10100	KSH10101	KSH10102	KSH10103	KSH10104
Stop drill setting tool	EWA 6 x 5-SM	EWA 6 x 15-SM	EWA 6 x 30-SM			
Item number	KSH10094	KSH10093	KSH10120			



Stop drill SDS 1



EWA 6 x 5



EWA 6 x 5-SM

\* Perm. Load to ETA-04/0026

K 6x... 0.8kN in accordance to ETA / -04/ 0026.

Suitable for non-load bearing applications.

Total partial safety anchor in accordance to

ETAG (Y<sub>M</sub> & Y<sub>F</sub>)

### CONSTRUCTION PRODUCTS SOLUTIONS INTERNATIONAL LTD.

Unit 3, Haslemere Industrial Estate, Pig Lane, Bishop's Stortford, Hertfordshire. CM23 3HG. United Kingdom.  
 Tel: +44(0)1279 505 514 - Fax: +44(0)1279 755190 - e mail: info@surecps-group.com - www.surecps-group.com  
 Company Reg. 6969591 VAT Reg. GB 824 4246 40



Please always wear the appropriate safety and protective clothing when installing fixing and anchor products. Always observe the necessary Health & Safety guidelines.

© All text copyright. Above information is given as guidance only and should always be verified by a suitable engineer.

The above information is given in good faith, and may be subject to alteration at any time without prior notification.



## K CONCRETE FIXING FOR MECHANICAL AND ELECTRICAL EQUIPMENT THROUGH INSULATION

### SureHit bolt anchor M6L

#### Application:

For the attachment of objects to the surface of thick insulation (Through fixing)

Available in the following materials:

- Zinc plated and passivated carbon steel
- Stainless steel A4 1.4404
- Stainless steel A5 1.4571
- Stainless steel A6 1.4529

The long fixing thickness allows the anchor to attach items to thick insulation

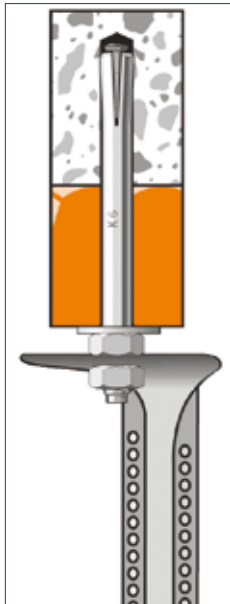
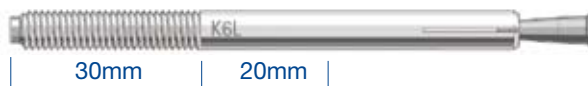

Bolt anchor	K 6x5/L	K 6x15/L	K 6x30/	K 6x50/30L	K 6x80/50L	K 6x110/50L
Item number	KSH7018	KSH7203	KSH7204	KSH7205	KSH7240	KSH7241
Box qty	200	100	100	100	100	100
Stop drill	SDS 2	SDS 2	SDS 2	SDS 2	SDS 2	SDS 2
Item number	KSH11007	KSH11007	KSH11007	KSH11007	KSH11007	KSH11007
Hand held setting tool	EWA	EWA	EWA	EWA	EWA	EWA
	6x5	6x15	6x30	6x50	6x80	6x110
Item number	KSH10099	KSH10100	KSH10101	KSH10102	KSH10103	KSH10104
Stop drill setting tool	EWA	EWA	EWA			
	6x5-SM	6x15-SM	6x30-SM			
Item number	KSH10094	KSH10093	KSH10120			

\* Perm. Load to ETA-04/0026  
K 6x.../L 1.45kN in accordance to ETA / -04/ 0026. Suitable for non-load bearing applications.  
Total partial safety anchor in accordance to ETAG (Y<sub>M</sub> & Y<sub>F</sub>)



Stop drill SDS 2



EWA 6 x 5



EWA 6 x 5-SM

### CONSTRUCTION PRODUCTS SOLUTIONS INTERNATIONAL LTD.

Unit 3, Haslemere Industrial Estate, Pig Lane, Bishop's Stortford, Hertfordshire. CM23 3HG. United Kingdom.  
Tel: +44(0)1279 505 514 - Fax: +44(0)1279 755190 - e mail: info@surecps-group.com - www.surecps-group.com  
Company Reg. 6969591 VAT Reg. GB 824 4246 40



Please always wear the appropriate safety and protective clothing when installing fixing and anchor products. Always observe the necessary Health & Safety guidelines.

© All text copyright. Above information is given as guidance only and should always be verified by a suitable engineer.

The above information is given in good faith, and may be subject to alteration at any time without prior notification.

## K8 CONCRETE FIXING FOR SUSPENDED CEILINGS, DROP RODS AND MECHANICAL/ELECTRICAL EQUIPMENT

### SureHit internal thread anchor

#### Application:

For use with drop rods, sprinkler systems, suspended ceilings and other M and E equipment

#### Available in the following materials:

Carbon steel  
Stainless steel (available upon request)



 Anchors meet the requirements of VdS for anchorage and fixing of fire sprinkler systems

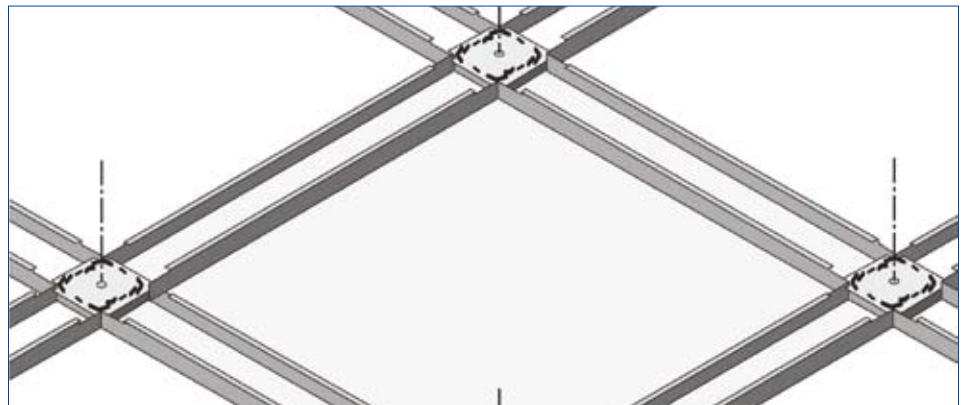
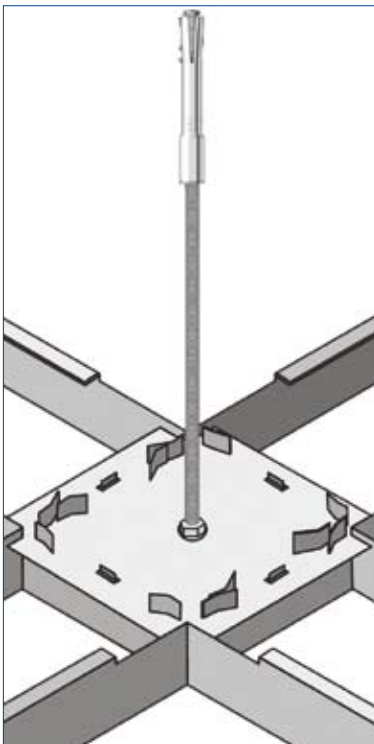

Internal Thread	K8 – M8/i	K8 – M10/i	K8 – M12/i	K8 – M8/ M10i
Item number	KSH7170	KSH7171	KSH7172	KSH7173
Box Qty	100	50	50	50
Stop drill	SDS 8x 43	SDS 8x 43	SDS 8x 43	SDS 8x 43
Item number	KSH11102	KSH11102	KSH11102	KSH11102
Stop drill setting tool	Si 8-SM	Si 10-SM	Si 12-SM	Si 8-SM
Item number	KSH10230	KSH10231	KSH10232	KSH10230

\* Perm. load in accordance to ETA /04/0026\*  
K8 [ all sizes] 1.45 kN. Fire resistance classification R120. For use with non-load bearing multiple fixing systems in cracked concrete. Total safety factors in accordance to ETAG (Y<sub>M</sub> & Y<sub>F</sub>)



Stop drill SDS 8 x 43



Si.- SM

6mm SureHit internal thread anchor available upon request.

### CONSTRUCTION PRODUCTS SOLUTIONS INTERNATIONAL LTD.

Unit 3, Haslemere Industrial Estate, Pig Lane, Bishop's Stortford, Hertfordshire. CM23 3HG. United Kingdom.  
Tel: +44(0)1279 505 514 - Fax: +44(0)1279 755190 - e mail: info@surecps-group.com - www.surecps-group.com  
Company Reg. 6969591 VAT Reg. GB 824 4246 40



Please always wear the appropriate safety and protective clothing when installing fixing and anchor products. Always observe the necessary Health & Safety guidelines.

© All text copyright. Above information is given as guidance only and should always be verified by a suitable engineer.

The above information is given in good faith, and may be subject to alteration at any time without prior notification.

Extract from the approval ETA 04/0026

Table 5: Installation Information

Anchor type	K6	K6 +	K6L	K8
Nominal drill diameter $d_0$ [mm]	6	6	6	8
Minimum drill depth $h_1 \geq$ [mm]	32	37	42	62
Minimum structural component thickness $h_{min}$ [mm]	80	80	80	100
Effective anchorage depth $h_{ef} \geq$ [mm]	26	31	36	56
Axial spacing $s_{cr} \geq$ [mm]	200			
Edge spacing $c_{cr} \geq$ [mm]	150			

Table 6: Design resistant values in accordance to design method C

Zinc plated anchor	K6	K6+	K6L	K8
<b>All load directions</b>				
Characteristic resistance in C20/25 C50/60 $F_{Rk}$ [kN]	2	2,5	5	5
Characteristic resistance in partial safety factor (inc. inst. partial factor $\gamma_2$ ) $\gamma_{M-1}$ [-]	1,8	1,8	2,52	2,52
<b>Shear load with lever arm</b>				
Characteristic bending moment $M_{RkS}^0$ [Nm]	3,6	7,7	18	
Partial safety factor $\gamma_{Ms-1}$ [-]	1.25			

In the case that no other regulations are applicable.

Applies to multiple fixing points for non-load bearing systems. For definition see ETAG 001 part 6 appendix 1

Characteristic bending moment marks for equation (5.5) in ETAG 001, appendix C

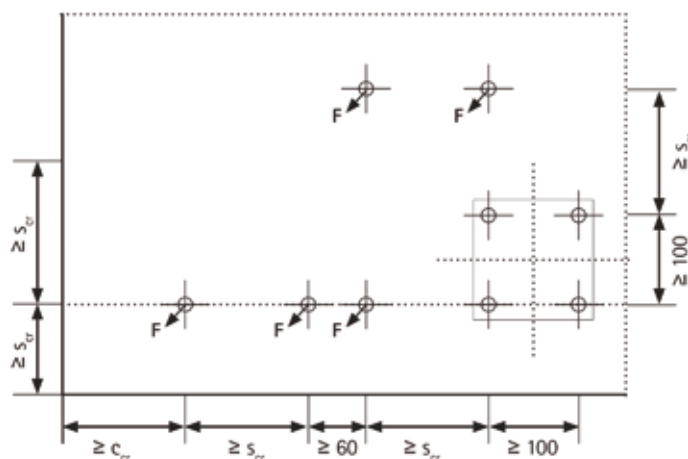

The design in accordance to table 6 are valid for a fixture. A fixture is considered to be:  
 Single anchor point  
 Pair of anchors  $S1 \geq 60$ mm  
 Group of 4 anchors  $S1 \geq 100$ mm

Anchor type zinc plated and passivated carbon steel	K6	K6+	K6L	K8
---	----	-----	-----	----

Perm. loads in consideration of the total partial safety factors $\gamma_M \gamma_F$	kN	0,80	1,00	1,45	1,45
Perm. load					

CONSTRUCTION PRODUCTS SOLUTIONS INTERNATIONAL LTD.

Unit 3, Haslemere Industrial Estate, Pig Lane, Bishop's Stortford, Hertfordshire. CM23 3HG. United Kingdom.  
 Tel: +44(0)1279 505 514 - Fax: +44(0)1279 755190 - e mail: info@surecps-group.com - www.surecps-group.com  
 Company Reg. 6969591 VAT Reg. GB 824 4246 40



Please always wear the appropriate safety and protective clothing when installing fixing and anchor products. Always observe the necessary Health & Safety guidelines.

© All text copyright. Above information is given as guidance only and should always be verified by a suitable engineer.

The above information is given in good faith, and may be subject to alteration at any time without prior notification.

## SUREHIT FIXING FOR SPRAYED CONCRETE REINFORCEMENT

SureHit fixing type DB for sprayed concrete reinforcement

### Application:

Spacer fixing to hold reinforcement off the surface of the concrete. Spacer may be removed for the direct attachment of reinforcement mesh to the surface of the concrete.

### Available in the following materials:

Zinc plated & passivated steel, stainless steel A4 1.4404

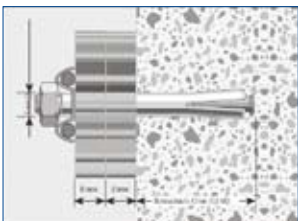
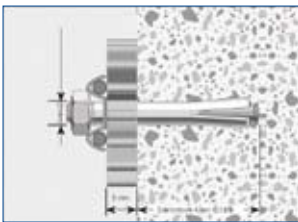
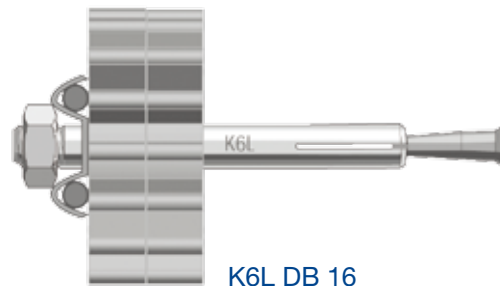

Fixing for Sprayed Concrete	K6L DB 8	K6L DB 16
Item number	KSH7505	KSH7506
Drill hole depth	42mm	42mm
Stop drill	SDS 3	SDS 3
Item number	KSH11012	KSH11012
Drill hole template	BL	BL
Item number	KSH10170	KSH1017



Stop drill SDS 3

Drill Hole Template



\* Perm. loads: In accordance to ETA -04/0026\* K6L 1.45 kN  
Fixing set consists of Surehit K6L fixing, attachment plate and either one or two plastic spacers.

### CONSTRUCTION PRODUCTS SOLUTIONS INTERNATIONAL LTD.

Unit 3, Haslemere Industrial Estate, Pig Lane, Bishop's Stortford, Hertfordshire. CM23 3HG. United Kingdom.  
Tel: +44(0)1279 505 514 - Fax: +44(0)1279 755190 - e mail: info@surecps-group.com - www.surecps-group.com  
Company Reg. 6969591 VAT Reg. GB 824 4246 40



Please always wear the appropriate safety and protective clothing when installing fixing and anchor products. Always observe the necessary Health & Safety guidelines.

© All text copyright. Above information is given as guidance only and should always be verified by a suitable engineer.

The above information is given in good faith, and may be subject to alteration at any time without prior notification.

## SUREHIT FIXING FOR SPRAYED CONCRETE REINFORCEMENT

### Ceiling Fixing KDM

#### Application:

Stand off fixing to hold reinforcement mesh for sprayed concrete with 20 mm thick spacer.

#### Available in the following materials:

Zinc plated & passivated steel, stainless steel A4 1.4404

#### Permissible loads:

In accordance to ETA - 04/0026\*

**KDM 0.80 kN**  
**KDM/L 1.45 kN**



CEILING FIXING	KDM SET	KDM/L SET	SPACER
Item number	KSH7022	KSH7020	KSH17086
Box qty	200	200	200
Stop drill	SDS 1	SDS 2	
Item number	KSH11002	KSH11007	
Setting tool for rotary hammer machine and stop drill	SWM SM 16	SWM SM 16	
Item number	KSH10207	KSH10207	
Set contents	200 fixings 1 Stop drill	200 fixings 1 Stop drill	
	Stop drill SDS 1	Stop drill SDS 2	



Stop drill SDS 1



Stop drill SDS 2



SWM-SM 16

### CONSTRUCTION PRODUCTS SOLUTIONS INTERNATIONAL LTD.

Unit 3, Haslemere Industrial Estate, Pig Lane, Bishop's Stortford, Hertfordshire. CM23 3HG. United Kingdom.  
Tel: +44(0)1279 505 514 - Fax: +44(0)1279 755190 - e mail: info@surecps-group.com - www.surecps-group.com  
Company Reg. 6969591 VAT Reg. GB 824 4246 40



Please always wear the appropriate safety and protective clothing when installing fixing and anchor products. Always observe the necessary Health & Safety guidelines.

© All text copyright. Above information is given as guidance only and should always be verified by a suitable engineer.

The above information is given in good faith, and may be subject to alteration at any time without prior notification.



## SUREHIT FIXING FOR SPRAYED CONCRETE REINFORCEMENT

### Surehit Sprayed Concrete Anchor with clamping plate Ø 6mm

#### Application:

The attachment of mesh reinforcement directly to the surface of concrete or firm substrates

#### Available in the following materials:

Zinc plated & passivated steel, stainless steel A4 1.4404

#### Supplied as:

Surehit Anchor, u washer and clamping plate 20 x 1.5 mm

#### Permissible loads:

In accordance to ETA -04/0026\*  
KDM 0.80 kN – KDM/L 1.45 kN

### Surehit Sprayed Concrete Anchor with clamping plate Ø 8mm

#### Application:

The attachment of mesh reinforcement directly to the surface of concrete or firm substrates

#### Available in the following materials:

Zinc plated & passivated steel, stainless steel A4 1.4404

#### Supplied as:

Surehit Anchor, u washer and clamping plate 20 x 1.5 mm

#### Permissible loads:

In accordance to ETA -04/0026\*  
K8 1.45 kN - Suitable for non-load bearing applications requiring multiple fixing points.  
Partial safety anchor in accordance to ETAG (Y<sub>M</sub> & Y<sub>F</sub>)

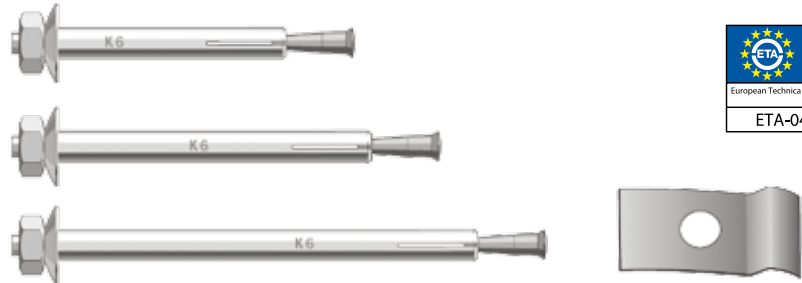

DESCRIPTION	KDM / L + CLAMPING PLATE	KDM / 6X30 N + CLAMPING PLATE	KDM / 6X50 N + CLAMPING PLATE
Item number	KSH3012	KSH3013	KSH3014
Box qty	100	100	100
Stop drill	SDS 2	SDS 3	SDS 4
Item number	KSH11007	KSH11012	KSH11013

Further sizes available upon request

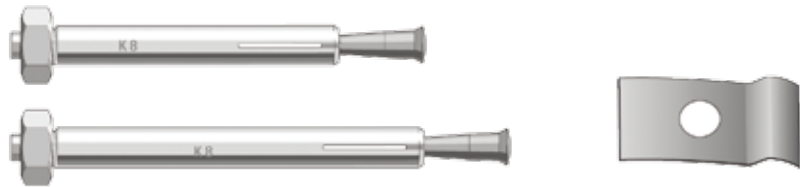

DESCRIPTION	8 X 70 + CLAMPING PLATE	8 X 90 + CLAMPING PLATE
Item number	KSH 3010	KSH 3011
Box qty	400	300

Further sizes available upon request



#### STOP DRILL TABLE

DESCRIPTION	FOR USE WITH ANCHOR	ITEM NUMBER
SDS 2	KDM/L	KSH 11007
SDS 3	KDM/ 6 x 30/N	KSH 11012
SDS 4	KDM/ 6 x 50/N	KSH 11013

Further sizes available upon request

#### CONSTRUCTION PRODUCTS SOLUTIONS INTERNATIONAL LTD.

Unit 3, Haslemere Industrial Estate, Pig Lane, Bishop's Stortford, Hertfordshire. CM23 3HG. United Kingdom.  
Tel: +44(0)1279 505 514 - Fax: +44(0)1279 755190 - e mail: info@surecps-group.com - www.surecps-group.com  
Company Reg. 6969591 VAT Reg. GB 824 4246 40



## KSS CONCRETE ACOUSTIC FIXING FOR SUSPENDED CEILING

SureHit Acoustic anchor  
KSS 1 and KSS 3- 35

**Application:**

For the reduction of sound transmission in structures primarily for dry lining and suspended ceilings

**Available in the following materials:**

Zinc plated and passivated carbon steel

**Optimum acoustic load 0.3kN**

A complete fixing assembly ensures the dampening qualities are achieved

KSS 1

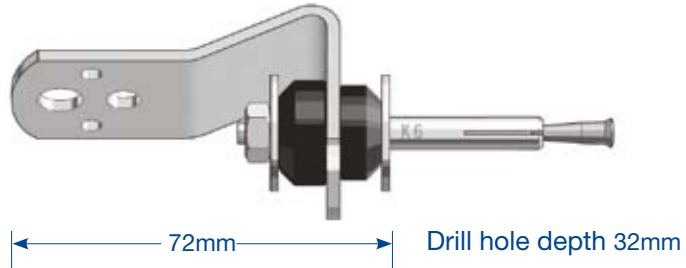

KSS 3-35

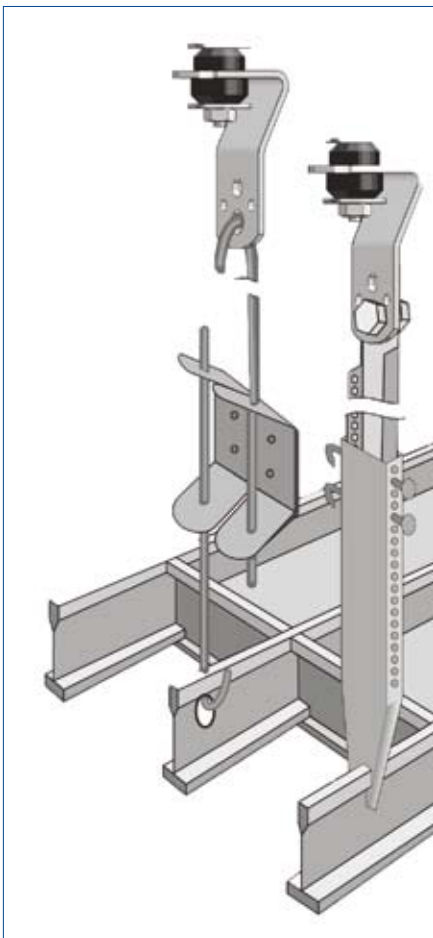
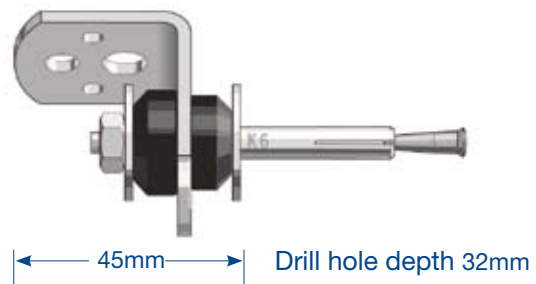

Acoustic fixings	KSS 1	KSS 3-35
Item number	KSH7500	KSH7504
Box Qty	100	100
Stop drill	SDS 1	SDS 1
Item number	KSH11002	KSH11002
Stop drill setting tool	SWM-SM 16	SWM-SM 16
Item number	KSH10207	KSH10207



Stop drill SDS 1



SWM-SM 16

CONSTRUCTION PRODUCTS SOLUTIONS INTERNATIONAL LTD.

Unit 3, Haslemere Industrial Estate, Pig Lane, Bishop's Stortford, Hertfordshire. CM23 3HG. United Kingdom.  
Tel: +44(0)1279 505 514 - Fax: +44(0)1279 755190 - e mail: info@surecps-group.com - www.surecps-group.com  
Company Reg. 6969591 VAT Reg. GB 824 4246 40



Please always wear the appropriate safety and protective clothing when installing fixing and anchor products. Always observe the necessary Health & Safety guidelines.

© All text copyright. Above information is given as guidance only and should always be verified by a suitable engineer.

The above information is given in good faith, and may be subject to alteration at any time without prior notification.

## CONCRETE- ACOUSTIC HANGER FIXING FOR THREADED ROD [DROP RODS]

Acoustic hanger fixing set  
KSS 2 -35

### Application

To reduce sound transmission for suspended ceilings using M6 & M8 drop rods.

Available in the following materials:  
Zinc plated and passivated steel

### Permissible Loads:

Optimum acoustic load 0.3 kN

The complete assembly of fixing, sound reducing rubber and hanger ensures that the sound transmissions are reduced through the floor slab

Installation is quick and simple

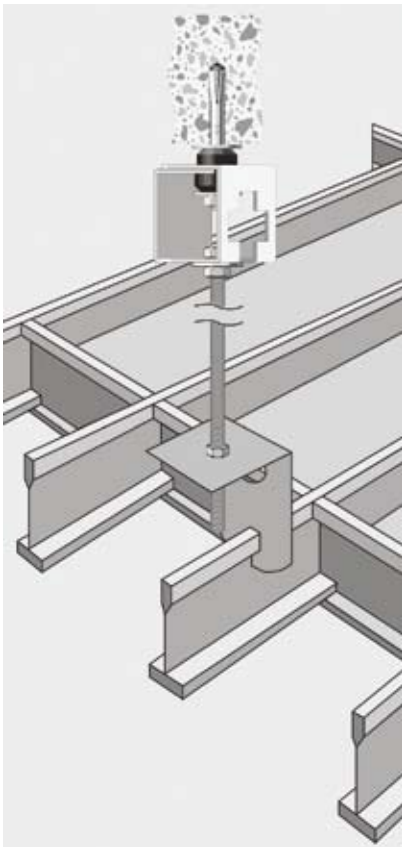
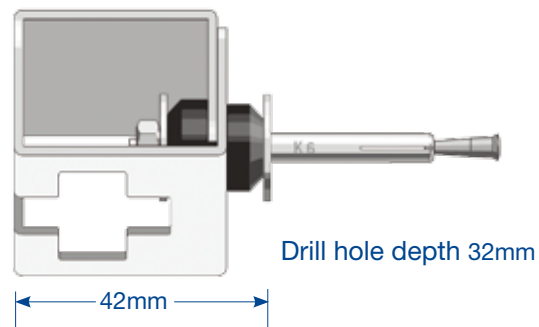

SureHit fixing with acoustic hanger	KSS 2 - 35
Item number	KSH7507
Box Qty	100
Stop drill	SDS 2
Item number	KSH11007



Stop drill SDS 2



Setting tool for rotary hammer drill

Perm. loads for multiple fixing points in cracked and non-cracked concrete.

### CONSTRUCTION PRODUCTS SOLUTIONS INTERNATIONAL LTD.

Unit 3, Haslemere Industrial Estate, Pig Lane, Bishop's Stortford, Hertfordshire. CM23 3HG. United Kingdom.  
Tel: +44(0)1279 505 514 - Fax: +44(0)1279 755190 - e mail: info@surecps-group.com - www.surecps-group.com  
Company Reg. 6969591 VAT Reg. GB 824 4246 40



Please always wear the appropriate safety and protective clothing when installing fixing and anchor products. Always observe the necessary Health & Safety guidelines.

© All text copyright. Above information is given as guidance only and should always be verified by a suitable engineer.

The above information is given in good faith, and may be subject to alteration at any time without prior notification.

## KSS CONCRETE ACOUSTIC FIXING FOR SOUND REDUCTION BETWEEN METAL COMPONENTS

### SureHit acoustic anchor KSS 3

#### Application:

For the reduction of sound transmission in structures, and the attachment of dry lining and suspended ceilings.

Available in the following materials:  
Zinc plated and carbon steel.

Optimum acoustic load 0.3 kN

KSS a complete fixing assembly ensures the dampening qualities are achieved.



Example of a ceiling fixed to concrete with the SureHit acoustic fixing

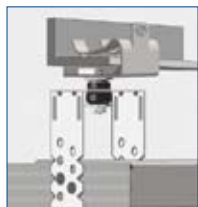

Example of the fixing attached to steel supporting a ceiling

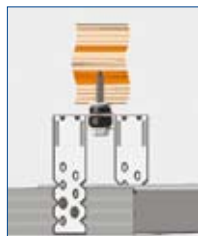

Example of the fixing attached to timber

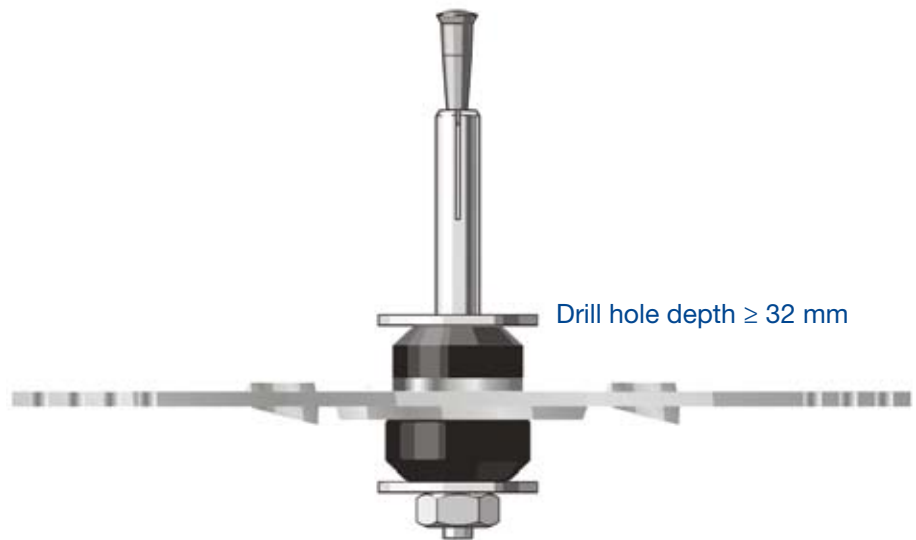

SureHit Kss acoustic fixing	60 mm	125 mm
Item Number	KSH7570	KSH7517
Box Qty	100	100
Stop drill	SDS 1	SDS 1
Item number	KSH11002	KSH11002
Stop drill setting tool	SWM-SM 16	SWM-SM 16
Item number	KSH10207	KSH10207



Stop drill SDS 1



SWM-SM 16

\* Perm. load in accordance to ETA / -04/ 0026.

Kmu 6 - Kmu 6L 0.80 kN

Kmu 8 - Kmu LF8 1.45 kN

Suitable for non-load bearing applications.

Total partial safety anchor in accordance to

ETAG (Y<sub>M</sub> & Y<sub>F</sub>)

### CONSTRUCTION PRODUCTS SOLUTIONS INTERNATIONAL LTD.

Unit 3, Haslemere Industrial Estate, Pig Lane, Bishop's Stortford, Hertfordshire. CM23 3HG. United Kingdom.  
Tel: +44(0)1279 505 514 - Fax: +44(0)1279 755190 - e mail: info@surecps-group.com - www.surecps-group.com  
Company Reg. 6969591 VAT Reg. GB 824 4246 40



## KHD ANCHOR FOR PRE-STRESSED HOLLOW CONCRETE PLANKS

### Application:

A heavy duty anchor for the attachment of objects to hollow concrete floor planks.



KHD flush fixing type B



Available in the following materials:

Zinc plated and Passivated carbon steel.

Stainless steel A4 1.4404

Optimum acoustic load 0.3 kN

Perm. loads:

Web thickness mm

≥ 25 0.70 kN

≥ 30 0.90 kN

≥ 40 2.0 kN

Hollow concrete plank anchor	KHD M6/10B	KHD M6/10B
Item number	KSH26601	KSH26631
Box Qty	100	100
Web thickness mm	≥ 25 ≤ 40	≥ 40
Drill Ø mm	10	10
SDS drill bit	10 x 100	10 x 100
Item number	KSH13016	KSH13016
Setting tool	EWA 6x50	EWA 6x50
Item number	KSH10102	KSH10102
Setting tool	BD 014 SW10/M6 1/4" 6-kt.	BD 014 SW10/M6 1/4" 6-kt.
Item number	KSH26133	KSH26133

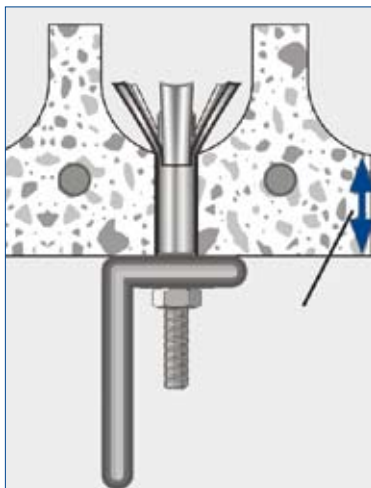

EWA 6 x 50



BD 014 SW 10/M6

Description	Suitable for anchor	Item number
SDS 4 Hammer Drill Bit	KHD M6 & KHD M6	KSH13016



Masonry drill bit 4 plus with SDS plus shaft

### CONSTRUCTION PRODUCTS SOLUTIONS INTERNATIONAL LTD.

Unit 3, Haslemere Industrial Estate, Pig Lane, Bishop's Stortford, Hertfordshire. CM23 3HG. United Kingdom.  
Tel: +44(0)1279 505 514 - Fax: +44(0)1279 755190 - e mail: info@surecps-group.com - www.surecps-group.com  
Company Reg. 6969591 VAT Reg. GB 824 4246 40



Please always wear the appropriate safety and protective clothing when installing fixing and anchor products. Always observe the necessary Health & Safety guidelines.

© All text copyright. Above information is given as guidance only and should always be verified by a suitable engineer.

The above information is given in good faith, and may be subject to alteration at any time without prior notification.



## T FIXING FOR HOLLOW PRE-STRESSED HOLLOW CONCRETE FLOOR PLANKS

### Application:

A light duty anchor for the attachment of objects to hollow concrete floor planks, including dry lining and suspended ceilings

### Available in the following materials:

Zinc plated and Passivated carbon steel.

### Perm. loads:

Web thickness mm	Perm. load kN
≥ 25	0.50 kN
≥ 30	0.80 kN
≥ 40	0.80 kN

### T fixing

Suspend with:

1. Nut and bolt
2. Wire clip

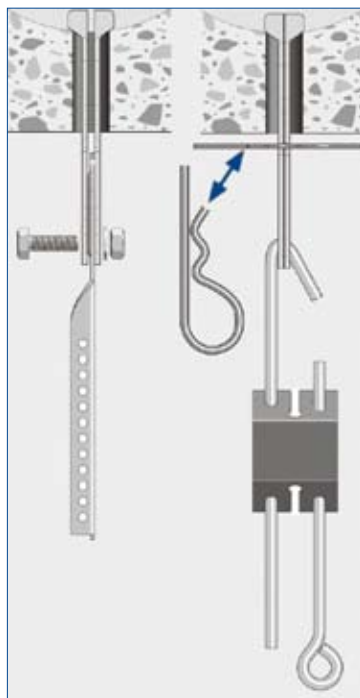
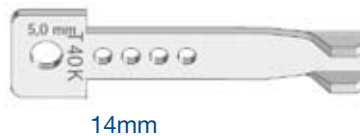

	SureHit TWIN	TWIN T 40	TWIN T 40 K	TWIN T 55
Item number		KSH26060	KSH26061	KSH26065
Box qty		100	100	100
Web thickness mm		≥ 25 - ≤ 40	≥ 25 - ≤ 40	> 40 - ≤ 55
Drill Ø mm		13	13	13
Wire clip				
Item number		KSH26063	KSH26063	KSH26063
Box qty		100	100	100
Nut and bolt M 6x20				
Item number		KSH26064	KSH26064	KSH26064
Box qty		100	100	100
SDS drill bit		13 x 100	13 x 100	13 x 100
Item number		KSH13056	KSH13056	KSH13056

Description	Suitable for anchor	Item number
SDS 4 Hammer Drill Bit	K55 M6 & K65 M6	KSH13056



Masonry drill bit 4 plus with SDS plus shaft

### CONSTRUCTION PRODUCTS SOLUTIONS INTERNATIONAL LTD.

Unit 3, Haslemere Industrial Estate, Pig Lane, Bishop's Stortford, Hertfordshire. CM23 3HG. United Kingdom.  
 Tel: +44(0)1279 505 514 - Fax: +44(0)1279 755190 - e mail: info@surecps-group.com - www.surecps-group.com  
 Company Reg. 6969591 VAT Reg. GB 824 4246 40



Please always wear the appropriate safety and protective clothing when installing fixing and anchor products. Always observe the necessary Health & Safety guidelines.

© All text copyright. Above information is given as guidance only and should always be verified by a suitable engineer.

The above information is given in good faith, and may be subject to alteration at any time without prior notification.

## PBD ANCHOR FOR AIRCRETE TO ATTACH HEAVY DUTY MATERIALS AND EQUIPMENT



### Applications:

- ▢ Mechanical and electrical services
- ▢ Air-conditioning
- ▢ Boilers, heaters, radiators
- ▢ Plumbing and pipework
- ▢ Framing systems
- ▢ Shelving

### Benefits:

- ▢ Eliminates the need for special tools or equipment
- ▢ 4 easy steps to install the SureHit anchor using either the hand held setting tool or power tool attachment
- ▢ Visual check for correct installation
- ▢ No pre-drilling required
- ▢ Stress-free fixing
- ▢ No waiting time for resin to set
- ▢ No hole cleaning required
- ▢ High load capacity
- ▢ Close edge and axial spacing
- ▢ Available in BZP and stainless steel materials
- ▢ Technical Approval
- ▢ Through fixing and internal thread anchors available
- ▢ Suitable for a wide range of applications: light-weight timber/aluminium facades, handrails, brackets, metal-work, sanitary ware, heating and ventilation equipment, radiators, framework and cladding materials.
- ▢ Approval for fire sprinkler systems



EWP – Hand held setting tool



EWP – SDS rotary hammer setting tool

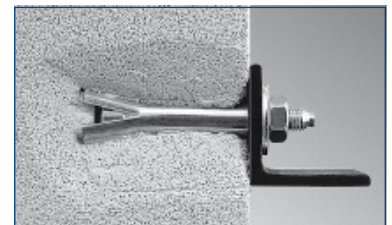
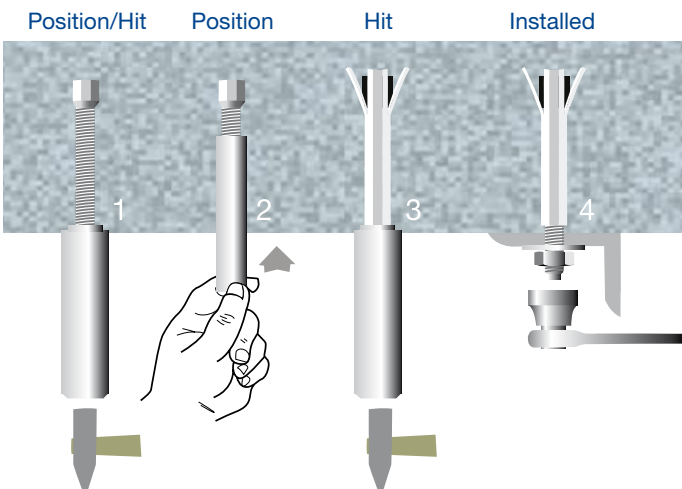

### CONSTRUCTION PRODUCTS SOLUTIONS INTERNATIONAL LTD.

Unit 3, Haslemere Industrial Estate, Pig Lane, Bishop's Stortford, Hertfordshire. CM23 3HG. United Kingdom.  
Tel: +44(0)1279 505 514 - Fax: +44(0)1279 755190 - e mail: info@surecps-group.com - www.surecps-group.com  
Company Reg. 6969591 VAT Reg. GB 824 4246 40



Please always wear the appropriate safety and protective clothing when installing fixing and anchor products. Always observe the necessary Health & Safety guidelines.

© All text copyright. Above information is given as guidance only and should always be verified by a suitable engineer.

The above information is given in good faith, and may be subject to alteration at any time without prior notification.

Permissible loads (Perm.F) for anchors subjected to tension, shear and oblique loads, installed in cracked and non-cracked aircrete

Anchor		SH-P M6/M8	SH-P M10/M12
		SH-I M6/M8	SH-P M10/M12
Single anchor Perm. F=kN			
Non-cracked aircrete		G2	0.4
		≥G4	0.8
Wall panels		GB 3.3	0.6
		GB 4.4	0.8
Cracked aircrete		GB 3.3	0.6
Roof and floor		GB 3.3	0.6
Panels (DIN 4223)		GB 4.4	0.8
Approved anchor spacing and structural component dimensions			
Anchor type		SH- P/SH-I	
Edge spacing / spacing to perp joint		$a_r \geq \text{cm}$	15
Edge spacing to bed joint		$a_{rl} \geq \text{cm}$	5
Min. axial spacing		$a_z \geq \text{cm}$	60
Min. structural component thickness		$d \geq \text{cm}$	17.5

The load values in this table are for permissible loads (safety factor included) and apply to both the zinc plated and stainless steel anchors

## Projection

Bolt Fixing	Item number	Fixing thickness	Box qty.	Hand held setting tool	Item number hand held setting tool	Item number HD setting tool
PBD M 6 x 10	KHS26201	10	25	EWP 6 x 10	KHS10051	KSH10057
PBD M 6 x 20	KHS26202	20	25	EWP 6 x 20	KHS10052	KSH10058
PBD M 6 x 30	KHS26203	30	25	EWP 6 x 30	KHS10053	KSH10059
PBD M 8 x 10	KHS26211	10	25	EWP 8 x 10	KHS10061	KSH10067
PBD M 8 x 20	KHS26212	20	25	EWP 8 x 20	KHS10062	KSH10068
PBD M 8 x 30	KHS26213	30	25	EWP 8 x 30	KHS10063	KSH10069
PBD M 10 x 10	KHS26221	10	25	EWP 10 x 10	KHS10071	KSH10077
PBD M 10 x 20	KHS26222	20	25	EWP 10 x 20	KHS10072	KSH10078
PBD M 10 x 30	KHS26223	30	25	EWP 10 x 30	KHS10073	KSH10079

## Internal

Internal bolt fixing	PBD I M6	PBD I M8	PBD I M10	PBD I M12
Item number	KHS26204	KHS26214	KHS26224	KHS26234
Internal thread depth mm	6 -13	8 - 13	8 - 13	8 - 13
Box qty.	25	25	25	25
Hand held setting tool	EWP 6 i	EWP 8 i	EWP 10 i	EWP 10 i
Item nr. EWA - handheld setting tool	KHS10054	KHS10064	KHS10074	KHS10074
Item nr. EWA - SDS rotary hammer setting tool	KHS10050	KHS10060	KHS10070	KHS10070

## CONSTRUCTION PRODUCTS SOLUTIONS INTERNATIONAL LTD.

Unit 3, Haslemere Industrial Estate, Pig Lane, Bishop's Stortford, Hertfordshire. CM23 3HG. United Kingdom.  
Tel: +44(0)1279 505 514 - Fax: +44(0)1279 755190 - e mail: info@surecps-group.com - www.surecps-group.com  
Company Reg. 6969591 VAT Reg. GB 824 4246 40



Please always wear the appropriate safety and protective clothing when installing fixing and anchor products. Always observe the necessary Health & Safety guidelines.

© All text copyright. Above information is given as guidance only and should always be verified by a suitable engineer.

The above information is given in good faith, and may be subject to alteration at any time without prior notification.

## KSH CLIC ARIEL CABLE FIXING SET

SureHit black clic cable clips.

**Application:**

For the support of radio cables.

Available in high quality nylon.

**Characteristics:**

- ▢ UV resistant resistant to a range of chemicals
- ▢ Resistant to road salts. Temperature resistant -40 °c – + 100 °c
- ▢ Installation at low temperature -24 °c



- ▢ Dark grey - DG
- ▢ Black - B

Item number	Description	Cable size mm	Imperial	Box Qty
KSH28620	Clic TOP 8 DG	7.8 - 9.5		100
KSH28621	Reducer	4		
KSH28622	Clic TOP 15 B	14.3 - 16.8	1/2	100
KSH28623	Clic TOP 17 B	16.8 - 19.5		100
KSH28624	Clic TOP 20 B	19.5 - 21.8	5/8	100
KSH28625	Clic TOP 22 B	21.8 - 24.8		100
KSH28626	Clic TOP 25 B	24.6 - 27.8		50
KSH28627	Clic TOP 28 B	27.8 - 31.2	7/8	50
KSH28628	Clic TOP 36 B	35.5 - 39.5	1 1/4	50
KSH28629	Clic TOP 47 B	46.5 - 50.5	1 5/8	50
KSH20060	Washer	M6 carbon steel		100
KSH20070	Washer	M6 stainless steel		100

Clic spacer cone installed in tunnels.



Item number	Description	Cone height	Box Qty	Case Qty
KSH28672	BHR-50	50	100	1000
KSH28674	BHR-80	80	100	550



Clic top



Clic clamp



Cones

CONSTRUCTION PRODUCTS SOLUTIONS INTERNATIONAL LTD.

Unit 3, Haslemere Industrial Estate, Pig Lane, Bishop's Stortford, Hertfordshire. CM23 3HG. United Kingdom.  
 Tel: +44(0)1279 505 514 - Fax: +44(0)1279 755190 - e mail: info@surecps-group.com - www.surecps-group.com  
 Company Reg. 6969591 VAT Reg. GB 824 4246 40



Please always wear the appropriate safety and protective clothing when installing fixing and anchor products. Always observe the necessary Health & Safety guidelines.

© All text copyright. Above information is given as guidance only and should always be verified by a suitable engineer.

The above information is given in good faith, and may be subject to alteration at any time without prior notification.

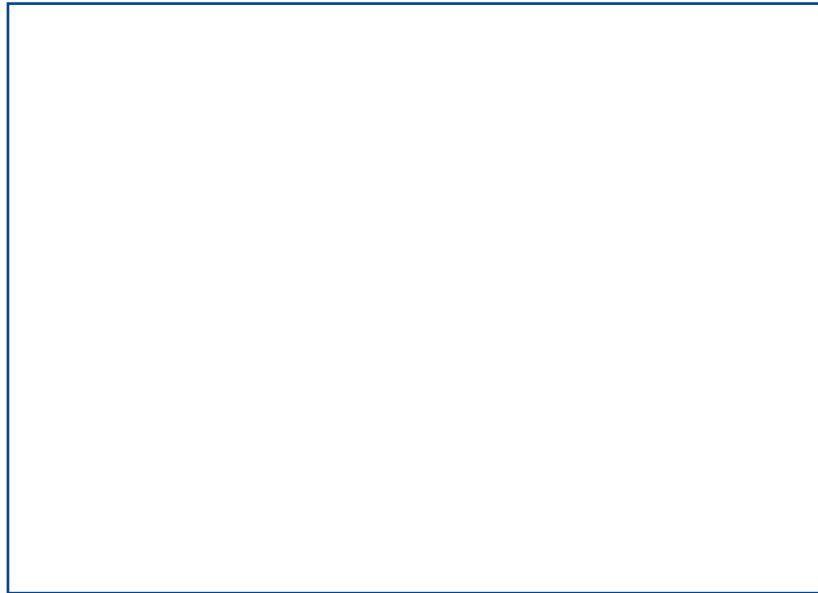

## Distributor



Refurbishment & Masonry Repair



General Construction & Civil Engineering



New Build Housing



Cladding / Facades & Curatin Wall



Mechanical, Electrical - Heating & Ventilation



Oil & Gas



Railway



Nuclear



Eco Build

## CONSTRUCTION PRODUCTS SOLUTIONS INTERNATIONAL LTD.

Unit 3, Haslemere Industrial Estate, Pig Lane, Bishop's Stortford, Hertfordshire. CM23 3HG. United Kingdom.  
Tel: +44(0)1279 505 514 - Fax: +44(0)1279 755190 - e mail: [info@surecps-group.com](mailto:info@surecps-group.com) - [www.surecps-group.com](http://www.surecps-group.com)  
Company Reg. 6969591 VAT Reg. GB 824 4246 40

